

Magnetic Sensor ICs

# Omnipolar Detection High Performance Low Power Hall-Effect Sensor IC

**AS1895**

## ● General Description

Using low power CMOS process, the AS1895 is designed for low power, high performance omnipolar detection hall-effect application, such as cover switch, contactless switch, solid state switch and lid close sensor etc battery operation. The hall IC integrated an on-chip hall voltage generator for magnetic sensing, a comparator that amplifiers the hall voltage, a Chopper amplifier, a Schmitt trigger to provide switching hysteresis for noise rejection, and a complementary output.

The total power consumption of AS1895 is typically less than 1.8uA at 1.8V power supply. AS1895 is designed to respond to alternating North and South poles. When the magnetic flux density (B) is larger than operate point ( $B_{OP}$ ), the output will be turned on (low), the output is held until the magnetic flux density (B) is lower than release point ( $B_{RP}$ ), then turn off (high).

The device is available in DFN1010-4L, DFN1216-4L, SOT553, SSOT23-3L and SOT23-3L Package and is rated over the  $-40^{\circ}\text{C}$  to  $85^{\circ}\text{C}$ . The all packages are RoHS and Green compliant.

## ● Features

- Input Voltage Range : 1.65V to 5.5V
- Micro-power consumption ideal for battery power applications
- Omnipolar Operation, easy to use as output
- Very high sensitivity hall sensor
- Low Power CMOS process technology
- Chopper stabilization amplifier stage
- Magnetic Sensitivity (typical)  
 $B_{OP} = \pm 30\text{Gauss}$ ,  $B_{RP} = \pm 20\text{Gauss}$
- Good RF noise immunity
- No need pull-up resistor
- Small Solution Size
- RoHS & Green Compliant
- DFN1010-4L, DFN1216-4L, SOT553, SSOT23-3L & SOT23-3L Packages
- $-40^{\circ}\text{C}$  to  $+85^{\circ}\text{C}$  Temperature Range

## ● Applications

- Cover switch in clam-shell cellular phones
- Cover switch in Notebook, PC/PAD
- Contact-less switch in consumer products
- Solid State Switch
- Handheld Wireless Handset Awake Switch
- Lid close sensor for battery-powered device
- Magnet proximity sensor for reed switch replacement in low duty cycle applications
- DV, DSC, and White Goods

■ **Ordering Information**

**AS1895XXX**

Package:  
 D: DFN1010-4L  
 D4: DFN1216-4L  
 D3: DFN2020-3L  
 W: SOT553  
 ST: SOT23-3L  
 S2: SSOT23-3L  
 M: SIP-3L

Packing:  
 R: Tape&Reel

Temperature Grade:  
 N: -40°C~85°C

Part Number	B <sub>OP</sub> (Gauss)	B <sub>RP</sub> Gauss)	Package Type	Package Qty	Temperature	Eco Plan
AS1895DRN	±30Gauss	±20Gauss	DFN1010-4L	7-in reel 10000pcs/reel	-40~85°C	Green
AS1895D4RN	±30Gauss	±20Gauss	DFN1216-4L	7-in reel 3000pcs/reel	-40~85°C	Green
AS1895D3RN	±30Gauss	±20Gauss	DFN2020-3L	7-in reel 4000pcs/reel	-40~85°C	Green
AS1895WRN	±30Gauss	±20Gauss	SOT553	7-in reel 3000pcs/reel	-40~85°C	Green
AS1895STRN	±30Gauss	±20Gauss	SOT23-3L	7-in reel 3000pcs/reel	-40~85°C	Green
AS1895S2RN	±30Gauss	±20Gauss	SSOT23-3L	7-in reel 3000pcs/reel	-40~85°C	Green
AS1895MRN	±30Gauss	±20Gauss	SIP-3L	1000pcs/package	-40~85°C	Rohs

■ **Marking & Pin Assignment**

**DFN1010-4L**

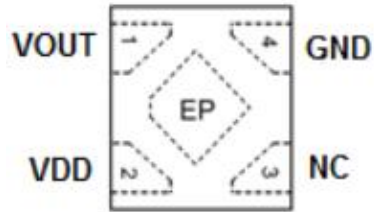
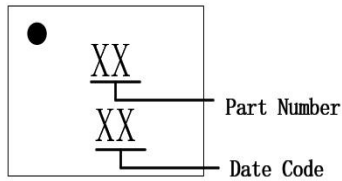

Pin Name	Pin No.	I/O	Pin Function
	DFN1010-4L		
VDD	2	P	Input Power Supply
GND	4	P	Ground
NC	3	-	Not Connected
OUTPUT	1	O	Output Pin

**DFN1216-4L:**

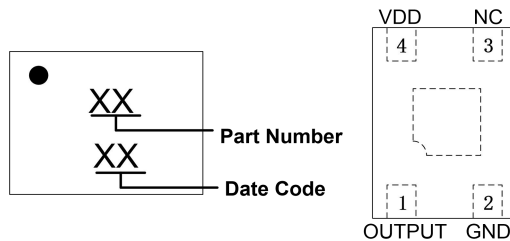

Pin Name	Pin No.	I/O	Pin Function
	DFN1216-4L		
VDD	4	P	Input Power Supply
GND	2	P	Ground
NC	3	-	Not Connected
OUTPUT	1	O	Output Pin

**DFN2020-3L**

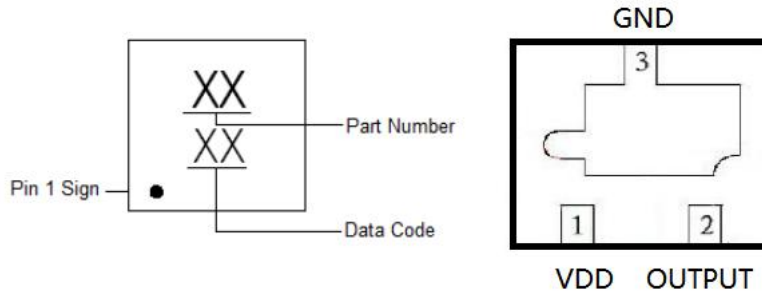

Pin Name	Pin No.	I/O	Pin Function
	DFN2020-3L		
VDD	1	P	Input Power Supply
GND	2	P	Ground
OUTPUT	3	O	Output Pin

**SOT553:**

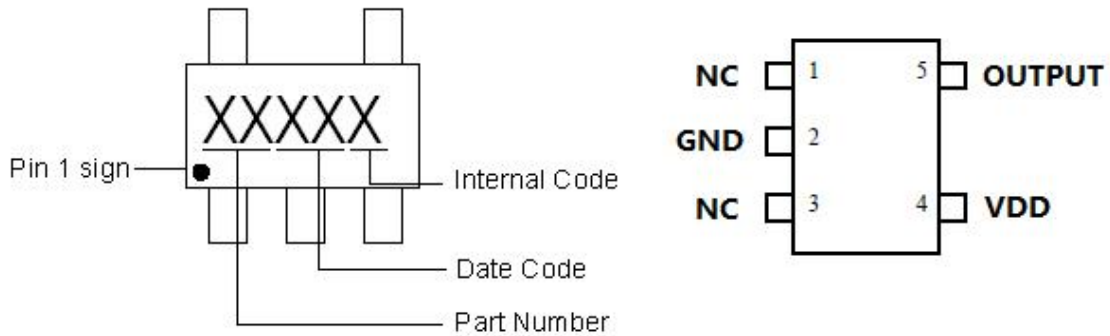

Pin Name	Pin No.	I/O	Pin Function
	SOT553		
VDD	4	P	Input Power Supply
GND	2	P	Ground
OUTPUT	5	O	Output Pin
NC	1,3	-	Not Connected

**SOT23-3L/SSOT23-3L:**

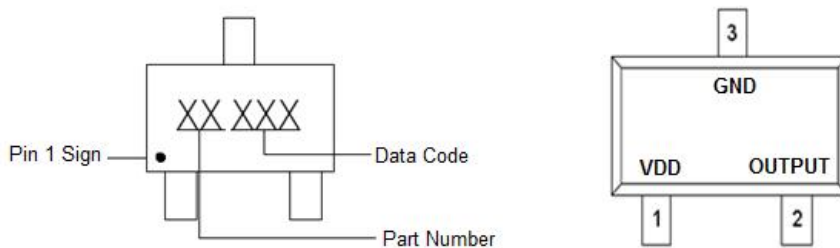

Pin Name	Pin No.	I/O	Pin Function
	SOT23-3L/SSOT23-3L		
VDD	1	P	Input Power Supply
GND	3	P	Ground
OUTPUT	2	O	Output Pin

SIP-3L

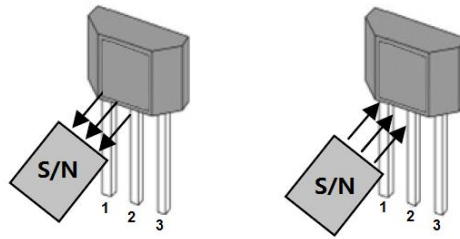

Pin Name	Pin No.	I/O	Pin Function
	SIP-3L		
VDD	1	P	Input Power Supply
GND	2	P	Ground
OUTPUT	3	O	Output Pin

■ **Typical Application Circuit**

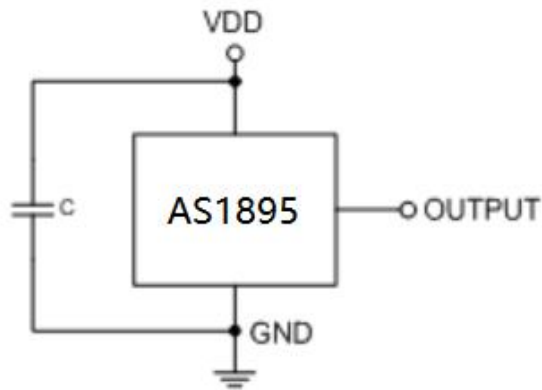

Figure 1, Typical Application Circuit of AS1895

■ **Block Diagram**

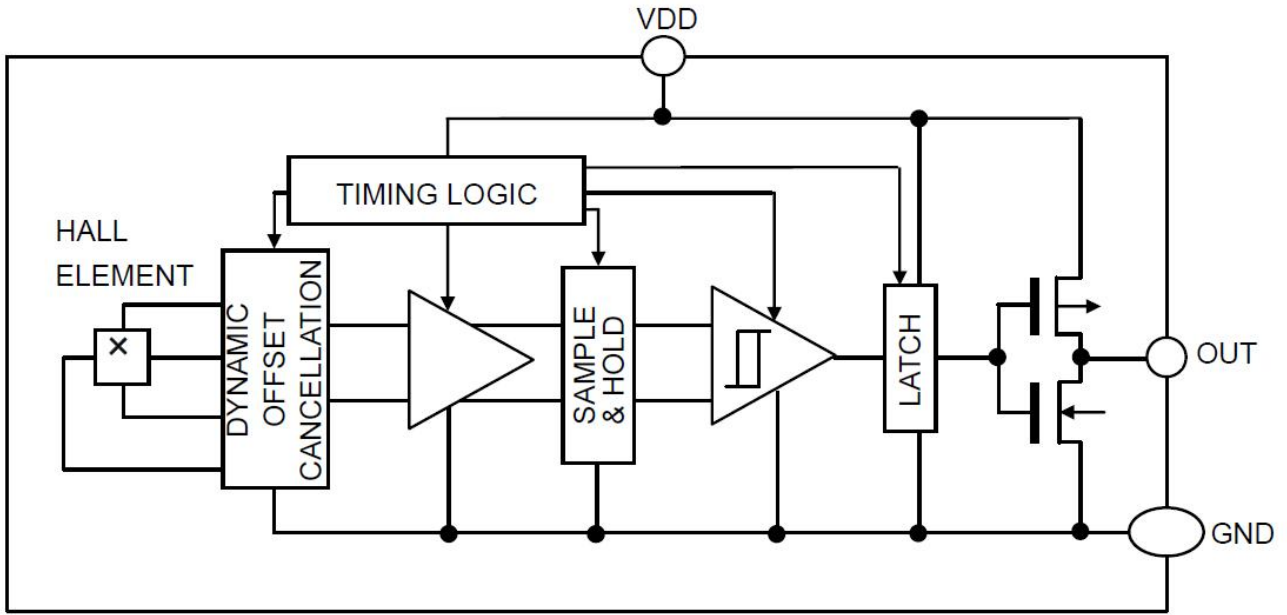

Figure 3, Block Diagram of AS1895

■ **Absolute Maximum Ratings<sup>1</sup>** ( $T_A=25^{\circ}\text{C}$ , unless otherwise noted)

Parameter	Symbol	Rating	Unit
$V_{DD}$ Pin to GND	$V_{DD}$	-0.3 to 6.0	V
Output Pin to GND	$V_{OUTPUT}$	-0.3 to $V_{DD} + 0.3$	V
Max. Continuous Output Current	$I_{OUTMAX}$	2.0	mA
Magnetic Flux Density	B	Unlimited	Gauss
Package Power Dissipation	DFN1216-4L/DFN2020-3L/ DFN1010-4L	250	mW
	SOT553/SOT23-3L	180	mW
ESD (HBM)	ESD	8000	V
Storage Temperature Range	$T_S$	-55 to +150	$^{\circ}\text{C}$
Operating Junction Temperature Range	$T_{OP}$	-40 to +150	$^{\circ}\text{C}$
Maximum Soldering Temperature (at leads, 10 sec)	$T_{LEAD}$	300	$^{\circ}\text{C}$

■ **Recommended Operating Conditions<sup>2</sup>**

Parameter	Symbol	Rating	Unit
$V_{DD}$ Pin to GND	$V_{DD}$	1.65 to 5.5	V
Continuous Output Current	$I_{OUT}$	1.0	mA
Operating Temperature Range	$T_{OP}$	-40 to +85	$^{\circ}\text{C}$

Note: 1: Stresses above those listed in absolute maximum ratings may cause permanent damage to the device. Functional operation at conditions other than the operating conditions specified is not implied. Only one absolute maximum rating should be applied at any one time.

2: The device is not guaranteed to function outside of its operating conditions.

■ **Electrical Characteristics**

( $T_A = -40$  to  $+85^\circ\text{C}$  unless otherwise noted. Typical values are at  $T_A = +25^\circ\text{C}$ ,  $V_{DD} = 3.3\text{V}$ )

Symbol	Parameter	Conditions	Min.	Typ.	Max.	Unit
$V_{DD}$	Input Voltage		1.65	3.3	5.5	V
$I_{DD(AVG)}$	Supply Current	Average supply current, $T_A = 25^\circ\text{C}$ , $V_{DD} = 1.8\text{V}$	-	1.8	3.0	$\mu\text{A}$
$I_{DD(AVG)}$		Average supply current, $T_A = 25^\circ\text{C}$ , $V_{DD} = 4.4\text{V}$	-	3.0	6.0	$\mu\text{A}$
$T_{awake}$	Awake Time		-	100	150	$\mu\text{s}$
$T_{period}$	Period		-	100	150	ms
D.C.	Duty Cycle		-	0.05	-	%
$V_{OH}$	Output Off Voltage (High side)	$I_{OUT} = +1\text{mA}$	$V_{DD} - 0.3$	$V_{DD} - 0.1$	$V_{DD} + 0.3$	V
$V_{OL}$	Output On Voltage (Low side)	$I_{OUT} = -1\text{mA}$	-0.3	0.1	+0.3	V

**Magnetic Para.**

$B_{OPS}$	Magnetic Operating Point		-	30	40	Gauss
$B_{OPN}$			-40	-30	-	
$B_{RPS}$	Magnetic Release Point		10	20	-	Gauss
$B_{RPN}$			-	-20	-10	
$B_{HYS}$	Hysteresis Window		-	10	-	Gauss

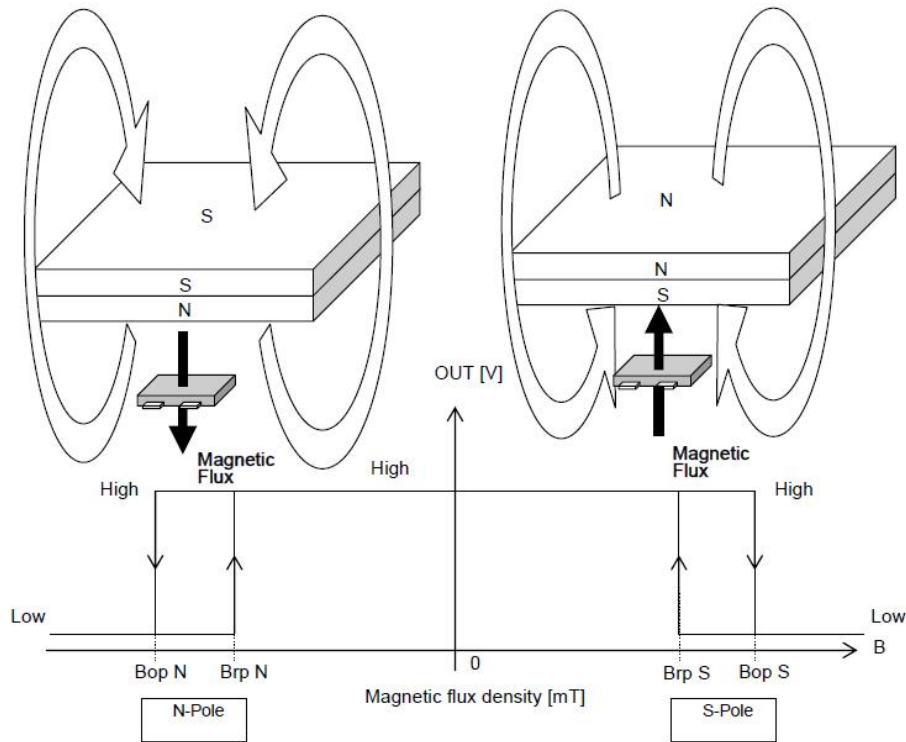
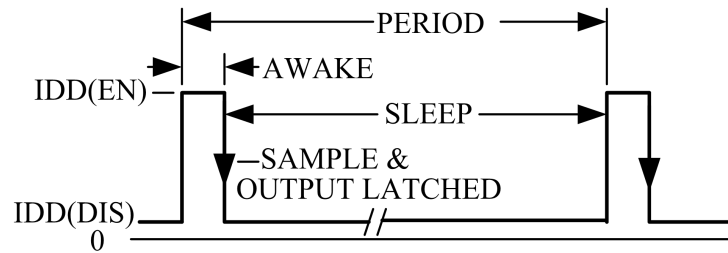

Fig 4, Magnetic Operation Characteristic of AS1895

■ **Function Description**



**Micro-power Operation**

Internal timing circuitry activates the sensor for 100µs and deactivates it for the remainder of the period (100ms). A short "awake" time allows for stabilization prior to the sensor sampling and data latching on the falling edge of the timing pulse. The output during the "sleep" time is latched in the last sampled state. The supply current is not affected by the output state.

**Chopper-Stabilized Technique**

The Hall element can be considered as a resistor array similar to a Wheatstone bridge. A large portion of the offset is a result of the mismatching of these resistors. These devices use a proprietary dynamic offset cancellation technique, with an internal high-frequency clock to reduce the residual offset voltage of the Hall element that is normally caused by device over-molding, temperature dependencies, and thermal stress. The chopper-stabilizing technique cancels the mismatching of the resistor circuit by changing the direction of the current flowing through the Hall plate using CMOS switches and Hall voltage measurement taps, while maintains the Hall voltage signal that is induced by the external magnetic flux. The signal is then captured by a sample-and-hold circuit and further processed using low-offset bipolar circuitry. This technique produces devices that have an extremely stable quiescent Hall output voltage, are immune to thermal stress, and have precise recoverability after temperature cycling. A relatively high sampling frequency is used for faster signal processing capability can be processed.

**Magnetic Field Detection Mechanism**

The Hall IC cannot detect magnetic fields that run horizontal to the package top layer. Be certain to configure the Hall IC so that the magnetic field is perpendicular to the top layer.

**Operation**

The output of this device switches low (turns on) when a magnetic field perpendicular to the Hall sensor exceeds the operate point  $B_{OPS}$  (or is less than  $B_{OPN}$ ). After turn-on, the output is capable of sinking up to 1mA and the output voltage is  $V_{OUT}(ON)$ . When the magnetic field is reduced below the release point  $B_{RPS}$  (or increased above  $B_{RPN}$ ), the device output switches high (turns off). The difference between the magnetic operates and release points are the hysteresis ( $B_{hys}$ ) of the device. This built-in hysteresis allows clean switching of the output even in the presence of external mechanical vibration and electrical noise.

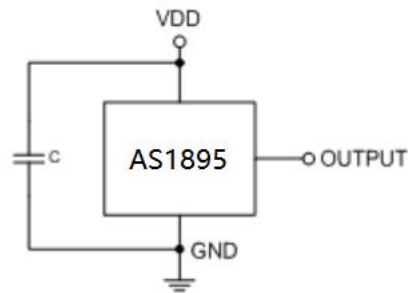
**Applications:**

AS1895's pole-independent sensing technique allows for operation with either a north or south poles magnet orientation, enhancing the manufacturability of the device. The state-of-the-art technology provides the same output polarity for either pole face.

C1 serves two purposes: minimizing ripples on the input voltage and enhancing immunity from RF transmission noises within close proximity. Recommended values are between 100nF and 1000nF. The larger the capacitance, the better the noise immunity is for the AS1895.

It is strongly recommended that an external bypass capacitor be connected (in close proximity to the Hall sensor) between the supply and ground of the device to reduce both external noise and noise generated by the chopper-stabilization technique. This is especially true due to the relatively high impedance of battery supplies. The simplest form of magnet that will operate these devices is a bar magnet with either pole near the branded surface of the device.

**Thermal Considerations**

The maximum IC junction temperature should be restricted to 125°C under normal operating conditions. This restriction limits the power dissipation of the AS1895. Calculate the maximum allowable dissipation,  $P_{D(max)}$ , and keep the actual dissipation less than or equal to  $P_{D(max)}$ . The maximum-power-dissipation limit is determined using following equation:

$$P_{D(MAX)} = \frac{125^{\circ}\text{C} - T_A}{R_{\theta JA}}$$

Where,  $T_A$  is the maximum ambient temperature for the application.  $R_{\theta JA}$  is the thermal resistance junction-to-ambient given in Power Dissipation Table.

■ Package Information

DFN1010-4L:

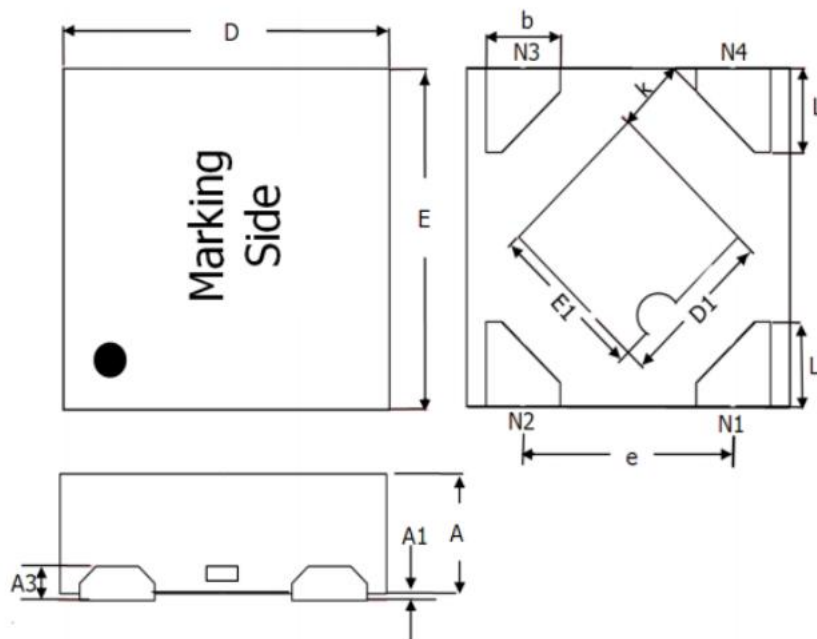

Symbol	Dimensions In Millimeters		Dimensions In Inches	
	Min.	Max.	Min.	Max.
A	0.340	0.400	0.014	0.016
A1	0.000	0.050	0.000	0.002
A3	0.152 BSC		0.006 BSC	
D	0.950	1.050	0.038	0.042
E	0.950	1.050	0.038	0.042
D1	0.450	0.550	0.018	0.022
E1	0.450	0.550	0.018	0.022
k	0.211 BSC		0.008 BSC	
b	0.180	0.280	0.0072	0.0112
e	0.625 BSC		0.025 BSC	
L	0.200	0.300	0.008	0.012

DFN1216-4L:

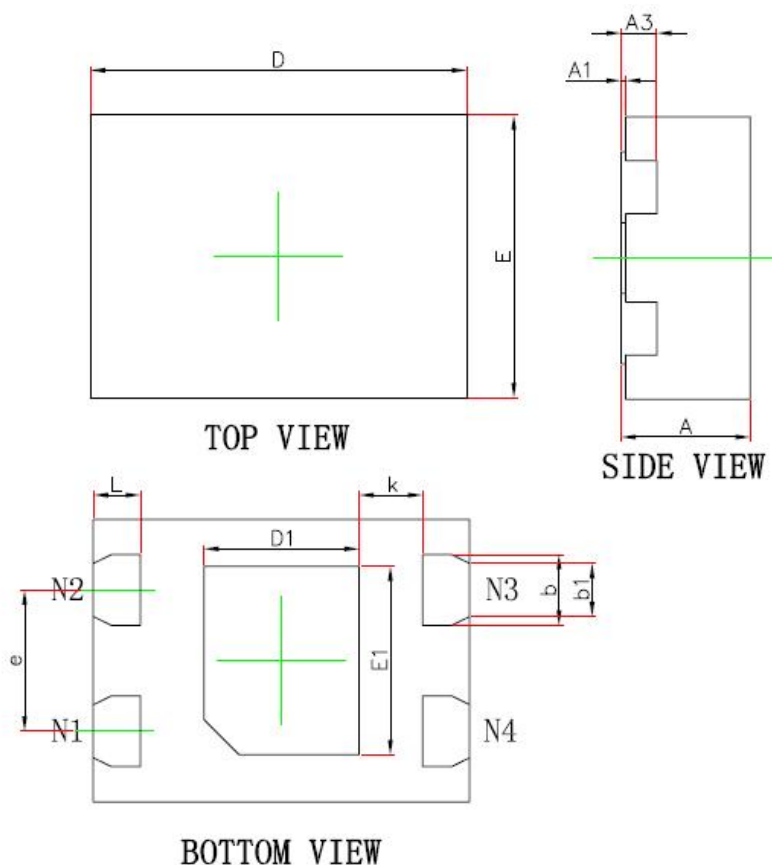

Symbol	Dimensions In Millimeters		Dimensions In Inches	
	Min.	Max.	Min.	Max.
A	0.320	0.400	0.013	0.016
A1	0.000	0.050	0.000	0.002
A3	0.102 (BSC)		0.004 (BSC)	
D	1.500	1.700	0.059	0.067
E	1.100	1.300	0.043	0.051
D1	0.440	0.640	0.017	0.025
E1	0.440	0.640	0.017	0.025
L	0.150	0.250	0.006	0.010
b	0.150	0.250	0.006	0.010
b1	0.150 (BSC)		0.006 (BSC)	
e	0.650 (BSC)		0.026 (BSC)	
k	0.330 (BSC)		0.013 (BSC)	

DFN2020-3L:

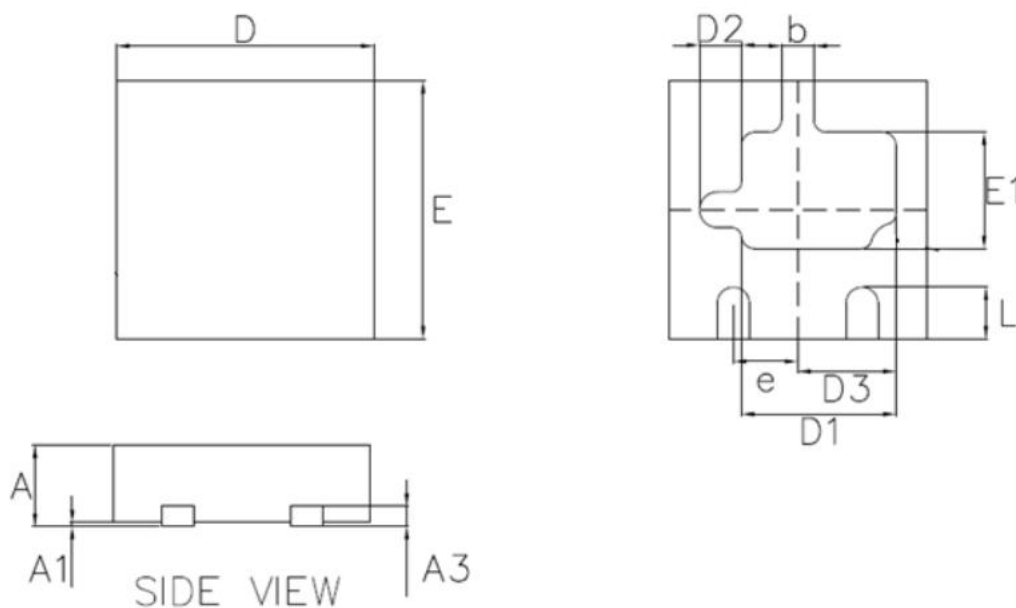

Symbol	Dimensions In Millimeters		Dimensions In Inches	
	Min.	Max.	Min.	Max.
A	0.500	0.600	0.020	0.024
A1	0.000	0.050	0.000	0.002
A3	0.150 (BSC)		0.006 (BSC)	
D	1.950	2.050	0.077	0.081
E	1.950	2.050	0.077	0.081
D1	1.100	1.300	0.043	0.051
E1	0.800	1.000	0.031	0.040
L	0.350	0.450	0.014	0.018
b	0.200	0.300	0.008	0.012
D2	0.325 (BSC)		0.013 (BSC)	
D3	0.670 (BSC)		0.026 (BSC)	
e	0.500 (BSC)		0.020 (BSC)	

SOT553:

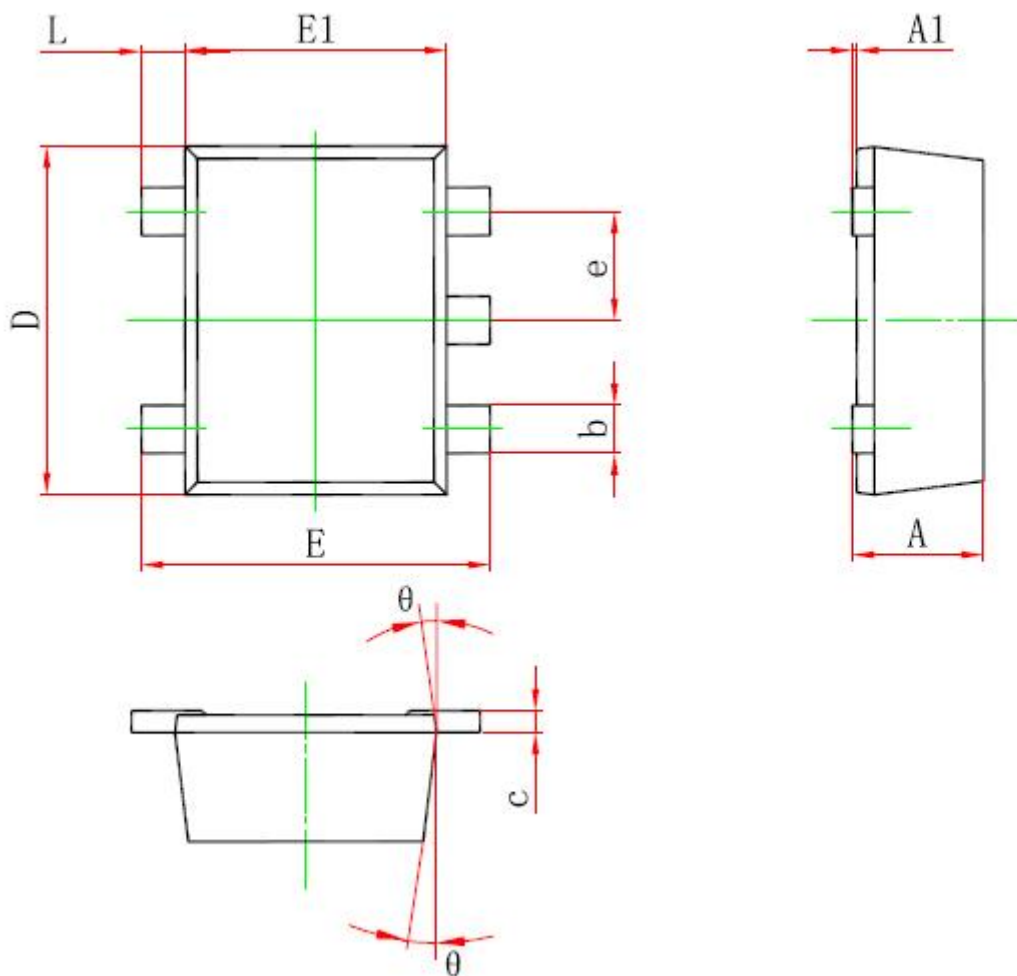

Symbol	Dimensions In Millimeters		Dimensions In Inches	
	Min.	Max.	Min.	Max.
A	0.525	0.600	0.021	0.024
A1	0.000	0.050	0.000	0.002
e	0.450	0.550	0.018	0.022
c	0.090	0.160	0.004	0.006
D	1.500	1.700	0.059	0.067
b	0.170	0.270	0.007	0.011
E1	1.100	1.300	0.043	0.051
E	1.500	1.700	0.059	0.067
$\theta$	7° REF		7° REF	
L	0.100	0.300	0.004	0.012

**SOT23-3L:**

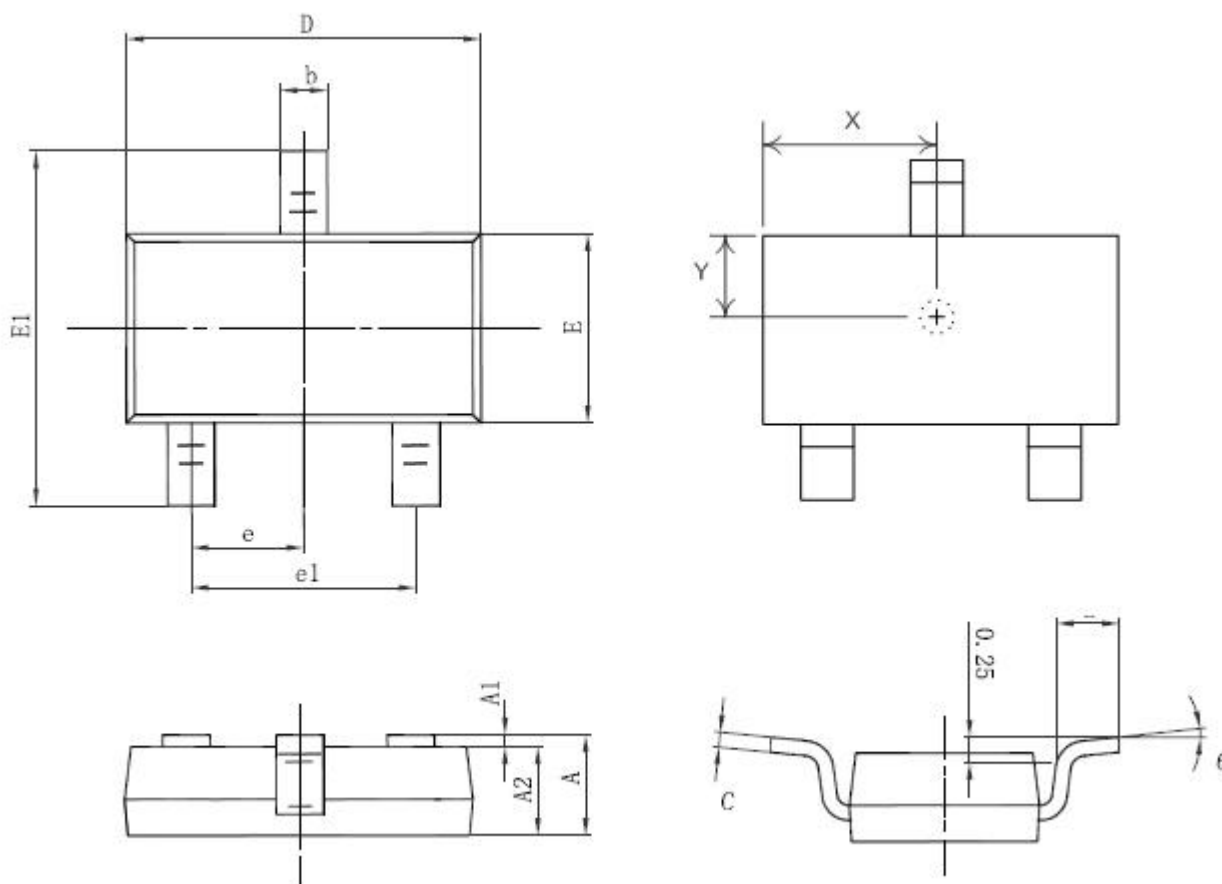

Symbol	Dimensions In Millimeters		Dimensions In Inches	
	Min.	Max.	Min.	Max.
A	1.050	1.250	0.041	0.049
A1	0.000	0.100	0.000	0.004
A2	1.050	1.150	0.041	0.045
b	0.300	0.500	0.012	0.020
c	0.100	0.200	0.004	0.008
D	2.820	3.020	0.111	0.119
E	1.500	1.700	0.059	0.067
E1	2.650	2.950	0.104	0.116
e	0.950(BSC)		0.037(BSC)	
e1	1.900(BSC)		0.075(BSC)	
L	0.300	0.600	0.012	0.024
$\theta$	0°	8°	0°	8°
X	1.410	1.510	0.056	0.059
Y	0.800	0.850	0.031	0.033

**SSOT23-3L:**

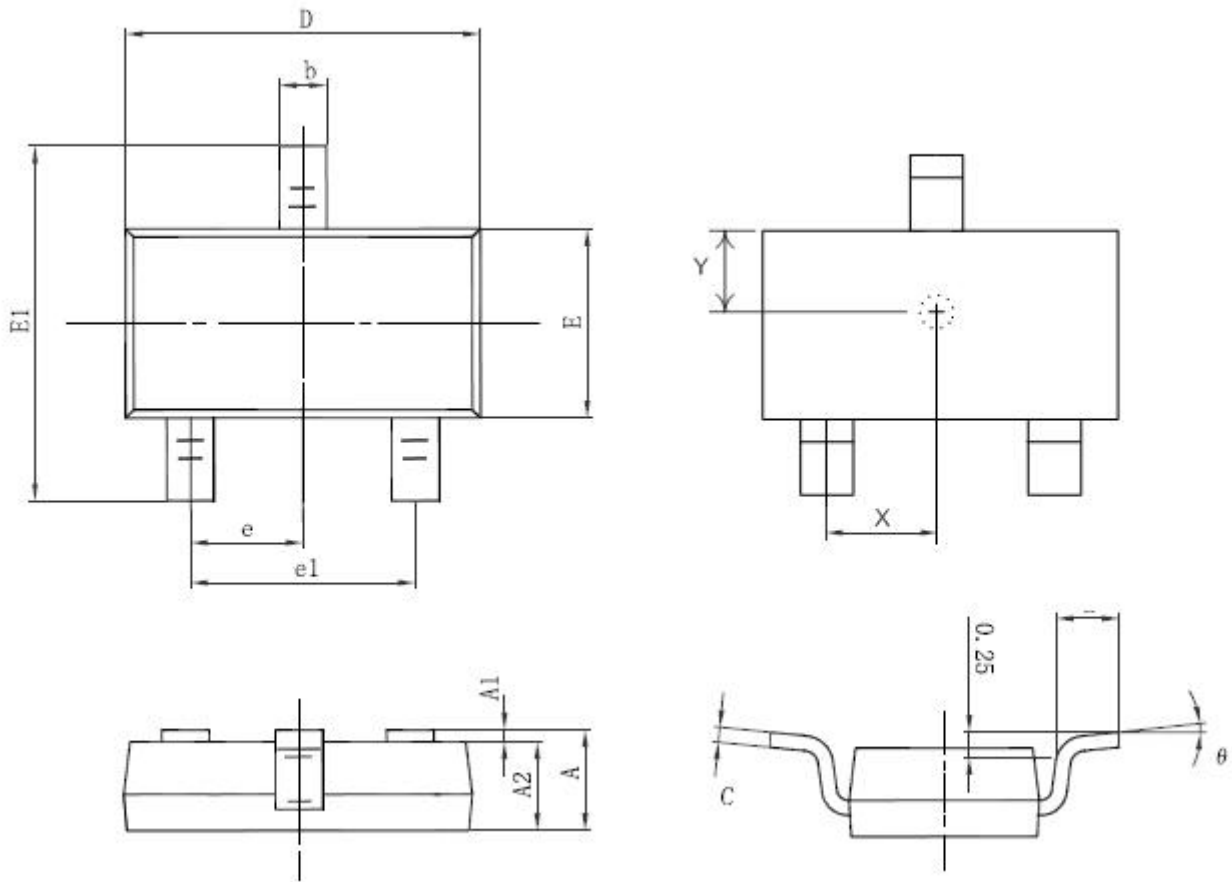

Symbol	Dimensions In Millimeters		Dimensions In Inches	
	Min.	Max.	Min.	Max.
A	0.900	1.150	0.035	0.045
A1	0.000	0.100	0.000	0.004
A2	0.900	1.050	0.035	0.041
b	0.300	0.500	0.012	0.020
c	0.080	0.150	0.003	0.006
D	2.800	3.000	0.110	0.118
E	1.200	1.400	0.047	0.055
E1	2.250	2.550	0.089	0.100
e	0.950(TPY)		0.037 (TPY)	
e1	1.800	2.000	0.071	0.079
L	0.550 REF		0.022 REF	
$\theta$	0°	8°	0°	8°
X	0.950(TPY)		0.037 (TPY)	
Y	0.700(TPY)		0.028 (TPY)	

**SIP-3L:**

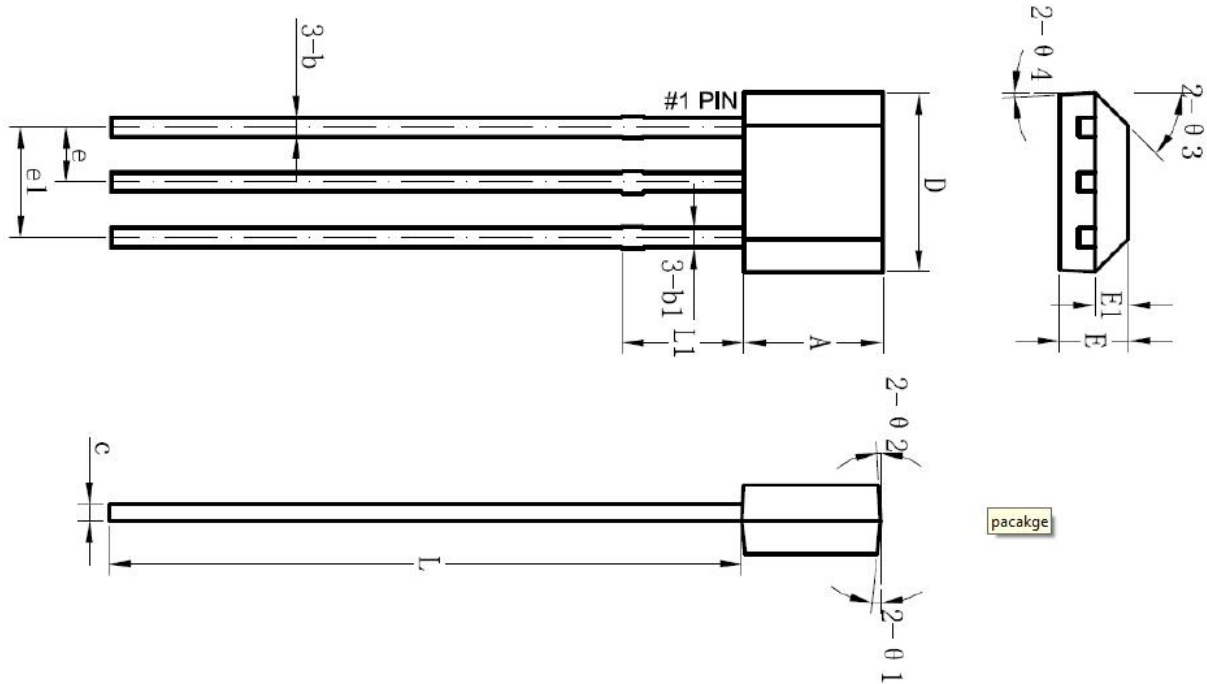

Symbol	Dimensions In Millimeters			Dimensions In Inches		
	Min.	Typ.	Max.	Min.	Typ.	Max.
A	2.900	3.000	3.100	0.114	0.118	0.122
b	0.350	0.390	0.560	0.014	0.015	0.022
b1	-	0.440	-	-	0.017	-
C	0.360	0.380	0.510	0.014	0.015	0.020
D	3.900	4.000	4.100	0.153	0.157	0.161
E	1.420	1.520	1.620	0.056	0.060	0.064
E1	-	0.750	-	-	0.030	-
e	-	1.270	-	-	0.050	-
e1	-	2.540	-	-	0.100	-
L	13.50	14.50	15.50	0.531	0.571	0.610
L1	-	1.600	-	-	0.063	-
θ1	-	6°	-	-	6°	-
θ2	-	3°	-	-	3°	-
θ3	-	45°	-	-	45°	-
θ4	-	3°	-	-	3°	-

■ **Packing Information**

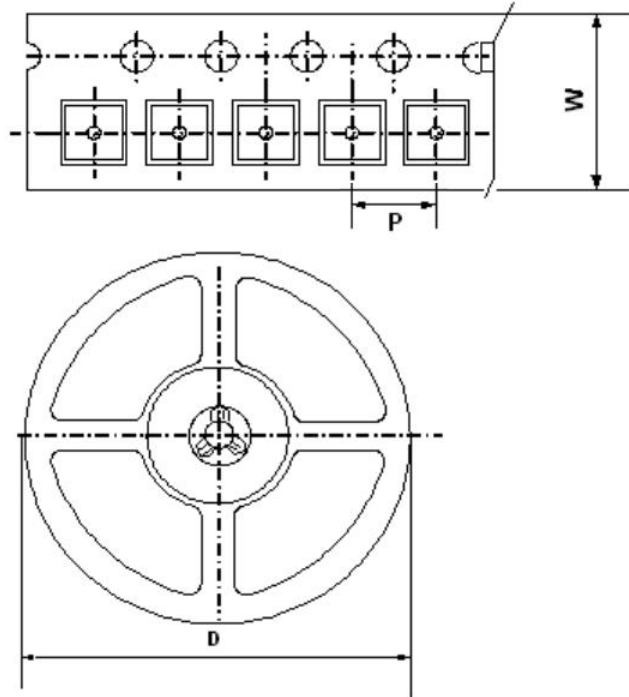

**QUADRANT ASSIGNMENTS FOR PIN 1 ORIENTATION IN TAPE**

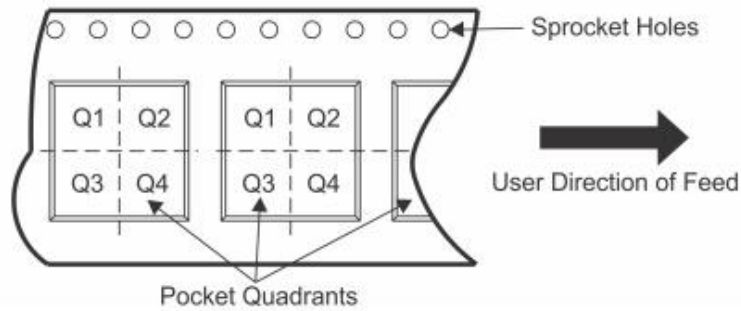

Device	Package Type	SPQ	Carrier Width (W)	Pitch(P)	Reel Size(D)	Pin1 Quadrant
AS1895DRN	DFN1010-4L	10Kpcs	8.0±0.1 mm	2.0±0.1 mm	180±1 mm	Q1
AS1895D4RN	DFN1216-4L	3000pcs	8.0±0.1 mm	4.0±0.1 mm	180±1 mm	Q2
AS1895D3RN	DFN2020-3L	4000pcs	8.0±0.1 mm	4.0±0.1 mm	180±1 mm	Q1
AS1895WRN	SOT553	3000pcs	8.0±0.1 mm	4.0±0.1 mm	180±1 mm	Q3
AS1895STRN	SOT23-3L	3000pcs	8.0±0.1 mm	4.0±0.1 mm	180±1 mm	Q3
AS1895S2RN	SSOT23-3L	3000pcs	8.0±0.1 mm	4.0±0.1 mm	180±1 mm	Q3

\*All dimensions are nominal

■ **Packing Information**

1. Packing type: Bulk
2. Packing minimum: 1000pcs